



# ARCTIC

## OUTSWINGING DOOR SYSTEMS

### High safety for high road speeds

Tamware's Arctic door is an outswinging plug door system designed specifically for intercity and long-distance coaches. The powerful door mechanism is positioned to the doorway side, leaving the doorway upper end free from other door components. This door is a common solution for long-

haul coaches and well-suited for high road speeds as the signature door sealing and locking mechanism ensure high stability in fast driving speeds and even on bumpy roads. Arctic doors can be used as a front, middle or rear door systems and in either single or double leaf versions.

# TAMWARE PRODUCT GROUPS



SAMPLE APPLICATIONS



## ARCTIC P-1L-R/L

**Application:**  
Bus/Coach  
**Recommended max. speed**  
120km/h  
**Actuator:**  
Pneumatic, single door

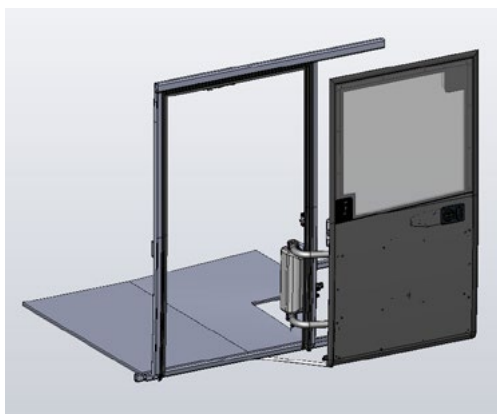

## ARCTIC P-2L-S

**Application:**  
Bus/Coach  
**Recommended max. speed**  
120km/h  
**Actuator:**  
Pneumatic, double door



PRODUCT INFORMATION

		Actuator location	Emergency releasing	Power requirement	Operating temperature options	Opening / closing time	Default safety features
ARCTIC P-1L-R/L	On the aperture wall	Mechanical, pneumatic	6-8 bar, nominal	-25°C ... +70°C	3-6 sec.	Sensitive edge/ pressure switches, position detection	
ARCTIC P-2L-S	On the aperture wall	Mechanical, pneumatic	6-8 bar, nominal	-25°C ... +70°C	3-6 sec.	Sensitive edge/ pressure switches, position detection	

All Tamware bus door products are designed according to EU Regulation ECE R107.



**Oy Tamware Ab**  
Yrittäjänkulma 5, FI-33710 Tampere, FINLAND  
Tel +358 3 2831 111  
sales@tamware.com, www.tamware.com